



PREMIER DECKING™

INSTALLATION GUIDE

AUGUST 2023

Pentarch Premier Decking™ is a solid hardwood timber product designed to be laid outdoors directly onto structural bearers and joists or used for fencing, screening, gates or seating.

Pentarch Premier Hardwood Decking is graded to 'standard and better', which is a mix of standard (medium feature) grade and select grade, in accordance with AS 2796.2-2006.

It is precision milled with round edges to a variety of widths with a smooth finish on both sides of the board. Pentarch Premier Decking™ is seasoned to the moisture requirements of AS 2796.1-1999 (10% to 18%).

This Installation Guide is intended to provide general advice on the installation of residential light domestic timber decks and does not apply to specialty applications or commercial decking.

Individual requirements may vary from those discussed in this Installation Guide and you are advised to seek independent professional advice before commencing work. You are also advised to check with State authorities to ensure building compliance as well as make your own, and/or seek an independent professional assessment of the relevant applicable laws and standards.

Building a deck in bushfire prone areas may require adherence to AS 3959-2018. Please also refer to Pentarch Forestry's Construction in Bushfire Zones Guide. Additional installation information including structural elements of other deck components (bearers, joists, footings etc) can be found in Wood Solutions Design Guide 21: Domestic Timber Deck. Customers in Queensland must also refer to the Construction Timber in Queensland guide available from the Queensland Department of Agriculture Fishery and Forestry.

Product Handling and Site Assessment

Pentarch Forestry's plastic wrapping is for protection during transportation only. Upon delivery timber decking products should be stored undercover and protected from the elements. Ensure boards are checked before installation in case of any damages during transport.

Timber is hygroscopic – meaning it is capable of easily absorbing and expelling moisture in response to local conditions. As timber absorbs moisture it expands and as it expels moisture it contracts. As such, factors such as relative humidity (atmospheric moisture), moisture ingress (underdeck or other), exposure to weather, lack of protective coatings or lack of adequate ventilation under the deck can compromise the timbers integrity.

Pre-Installation Preparation

Preparation is important and adequate ventilation is required above and below the deck. Pentarch Forestry recommends decking be installed a minimum of 400mm above ground to ensure optimum ventilation and performance. Determine the dimensions of the deck and note the position of features such as stairs, drains, and pipes as these will need to be marked up before any work begins. Ensure the ground is clear and weed control is undertaken prior to installing the deck.

Ensure adequate drainage to avoid build-up of water underneath the deck. Unobstructed air flow is required below the deck so add vents at various locations for decks with limited ventilation. To allow for offcuts and joining boards over joists a 10% waste factor is considered standard industry practice. Pentarch Premier Decking™ is graded as per AS 2796.2-2006 to one face of the decking board only.

To allow for offcuts and joining boards over joists a 10% waste factor is considered standard industry practice. Pentarch Premier Decking™ is graded as per AS 2796.2-2006 to one face of the decking board only.



Fixings

Each board should be fixed to each joist with two nails as required by AS 1684 with required fixings for domestic decking. Alternatively, proprietary fixings such as screws or concealed fixing systems may be used in accordance with manufacturer's instructions.

Only hot dipped galvanised or stainless steel (not plain steel or zinc plated) nails should be used to fix decking to joists. Stainless steel or silicon bronze fixings are recommended for decks built within 1m of water such as pools, ponds, etc.

Pre-drilling is recommended prior to installation of screws or nails.

At intermediate fixings, nails should either be offset or driven at slightly opposing angles (Diagram 1.0).

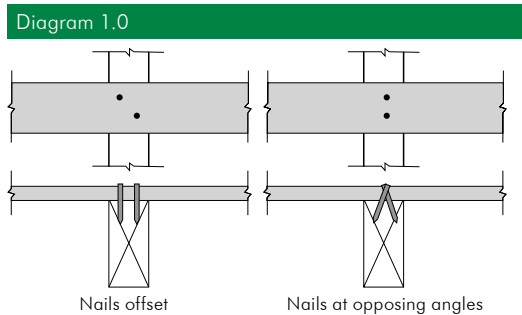

Installation Requirements

Pentarch Premier Decking™ is designed for bearers and joists that are structurally sound as per the AS 1720 and compliant with the National Construction Code (NCC). Decking should be nailed or screwed with suitable fixings directly to bearers and joists. When used for fencing it can be screwed into timber or steel posts. Installation standards for decking products is outlined in the AS 1684 and AS 1720.

Deck installation requirements are based on decks at least 400mm above ground. For decks under 400mm or close to water please refer to the section below (close to ground or close to water decks) for additional considerations.

Always adhere to all NCC regulations, local council and building authority requirements and determine if the decking product you are using is fit for your intended purpose. Residential joist span recommendations for 19mm Pentarch Premier Decking™ is 450mm centres maximum. Pentarch Premier Decking™ 600series 22mm in Spotted Gum can span 600mm maximum joist centres (Standard & Better grade only).

For 45 degree board installation joists spans will need to be 300mm maximum. Joist spans for commercial or specialty applications will need to be determined by a qualified professional.

To compensate for expansion decking boards must be properly spaced during installation. For boards up to 90mm wide use a minimum gap of 3mm and for boards over 90mm wide use a minimum gap of 5mm. Close to ground decks (under 400mm) require an 8mm gap between boards regardless of board width.

Bushfire zones may have specific gapping requirements.

When fixing joints stagger the joints so they do not sit on adjoining joists to avoid joists splitting. Make sure that all joints in the boards sit over a joist (Diagram 2.0).

Diagram 2.0

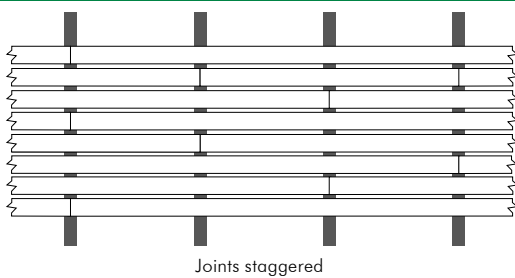
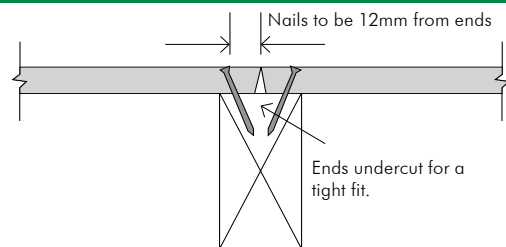

Diagram 3.0



To obtain a tight fit on the joints a slight undercut will assist with the boards sitting flush (Diagram 3.0). Pre-drill nail holes (80% of nail diameter) into the board to avoid splitting. Nails must be kept 12mm from edges and ends of boards (Diagram 3.0). Nails must be driven flush with surface (not punched). Each board should be nailed to each joist with two nails as required by AS 1684 for required fixings for domestic decking.

Machine-driven nail properties usually vary between nailing gun manufacturers and are considered proprietary to the manufacturer. Machine-driven nails can be used as long as the nail capacity is the same as the hand-driven nails. Care is required when using machines to ensure the nail head is not driven below the surface of the board.

As is the case for machine-driven nails, screw requirements are not referenced in AS 1684. The principles described above for machine nails should be followed for screws. Types of screws are usually proprietary information and reference to the manufacturer's installation requirements should be followed.

Alternatively, proprietary fixings such as concealed fixing systems may be used in accordance with manufacturer's instructions.

Close To Ground or Close To Water Decking

Although performance of timber decking close to ground or within 1m of water cannot be guaranteed Pentarch Forestry recommends the following installation practices when installing in these environments.

Timber is a natural product and close to ground or close to water installations are highly prone to cause above average expansion, contracting, cupping and warping of the decking boards. The use of narrower boards 64-90mm is recommended in these situations and an 8mm gap between the boards is required to assist with increasing the airflow between and beneath the boards. Coat all sides of the boards before install (including the underside and ends).

Decks less than 400mm from the ground or within 1 metre of a pool also require additional considerations such as increased ventilation, highly durable timber species selection, access for termite inspection, subsurface drainage, fastener durability considerations, more frequent re-coating and maintenance. Weather conditions such as but not limited to excessive rain, hot sun and winds can also affect deck performance.

Finger Jointed Decking

Pentarch Forestry's Finger Jointed has been tested and accredited for use in internal and external domestic applications. Pentarch Forestry is a member of the EWPA who have issued DTS certification for this product under their special products certification scheme. Refer to the Product Technical Statement for further information.

The finger jointed decking should be installed as per all the requirements of this install guide including but not limited to handling, fixings, spacings and finishes. To maintain its structural integrity, finger jointed decking must be installed with the correct face up as nominated by the sectional view below and the arrows printed on the sides of the board.

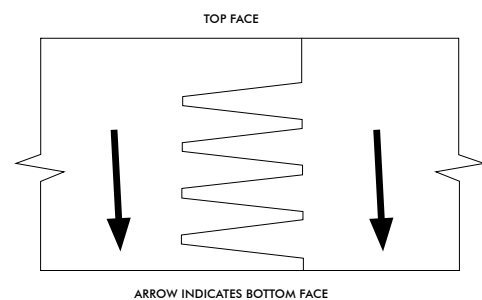

Timber Finishes

If your decking has been supplied pre-oiled from Pentarch Forestry please also refer to the separate pre-oiled installation guidelines.

After a new timber deck has been built, or an existing deck repaired, it must be thoroughly swept and cleaned to remove metal filings from drilling, nailing or other construction that may cause black spots. If the deck has turned grey from natural weathering or is discoloured due to metal filings or other construction materials,

there are a large range of maintenance and cleaning products on the market which may help bring it back to its natural beauty.

Timber coatings help protect the surface of the timber from the effects of weathering and slow down the rate at which timber will take up or loose moisture. By slowing down that rate the severity of any checking on the surface of the timber is reduced considerably. When applying protective finishes please ensure manufacturer's instructions are followed.

The protective finish should be applied to all surfaces (including cut ends) of each decking board before fixing to the joists.

A protective finish includes products that penetrate the surface of the timber (such as oils and stains) and products that provide a film or coating to the surface of the timber (such as paints and clear coatings).

Pentarch Premier Decking™ is supplied kiln dried as per Australian Standards between 10% and 18%. Increasing the decking's moisture content above 20% (refer Keith Bootle's Wood in Australia, 2nd edition 2005) due to lack of adequate protection can make the timber susceptible to very fine spores of fungi that are abundant in the air. Should your decking show signs of mould on the surface please consult a coatings manufacturer for a suitable mould removal product.

Further information on timber finishes can be found in **Wood Solutions Design Guide #13: Finishing Timber Externally**.

Deck Care and Maintenance

Pentarch Forestry recommends an inspection of your hardwood deck every 6 to 12 months however this may vary depending on the location of the deck and the type and quality of finishes used. The deck should be cleaned regularly and any loose or damaged boards or fixings should be resecured or replaced. When cleaning the deck, avoid hosing it down; use a broom or a blower instead.

As timber is a natural product checks (small cracks) may appear over time on the surface of the boards. These small cracks have no structural effect and are part of the timbers character. They are caused by the periodic wetting and drying of the decking and this natural process can be slowed by the protective properties of finishes.

Without regular maintenance decking boards may discolour and the surface can become rough and prone to splinters. A poorly maintained deck is also susceptible to mould which can make the surface slippery or reduce the service life of the decking boards.

Tannin Stains

Tannins are water soluble extractives found in most hardwoods which may leach onto surrounding surfaces whenever moisture leaves the timber.

Tannin stains can be difficult to remove especially from unsealed masonry surfaces. Some species have been reported to be less problematic than others however the best way to lessen the likelihood of tannin bleed is to coat all sides of the timber with a suitable finish.

Safe Work Practices

All safety standards set by Safe Work Australia must be followed, including the following practices when working with timber: Work areas must be clean. Sawing, sanding and routing equipment should be fitted with dust extractors. Dust levels should be below standards set by Safe Work Australia for wood dust. When machining timber respiratory protection, gloves, clothing, hearing and eye protection should be worn.

After handling timber, wash skin thoroughly with mild soap and regularly wash clothing. For any treated timber, do not burn offcuts or sawdust. Preservative treated offcuts and sawdust should be disposed of by approved local authority methods.





Responsible Wood[™]
RW/1-31-217



PEFC[™]
PEFC/21-31-217

Sustainably Grown. Australian Made.

Photo Credit: Front cover & internal page by 'Hammer and Heels Renovations'

Note: Variations within a timber species are normal, therefore photographs, samples and displays can only be indicative of colour and should not be used for final selection. It is normal for natural timber products to react to changes in atmospheric and environmental conditions such as humidity and temperature.

pentarchforestry.com.au

National free call 1800 818 317

©2023 PENTARCH FORESTRY PTY LTD (ABN 22 159 663 420). Pentarch Forestry and the Pentarch Forestry logo are trade marks or registered trade marks of PENTARCH FORESTRY PTY LIMITED or one of its subsidiaries. PEN_0135



PENTARCH
FORESTRY[™]